

Aristo[®]

Tig 4000i

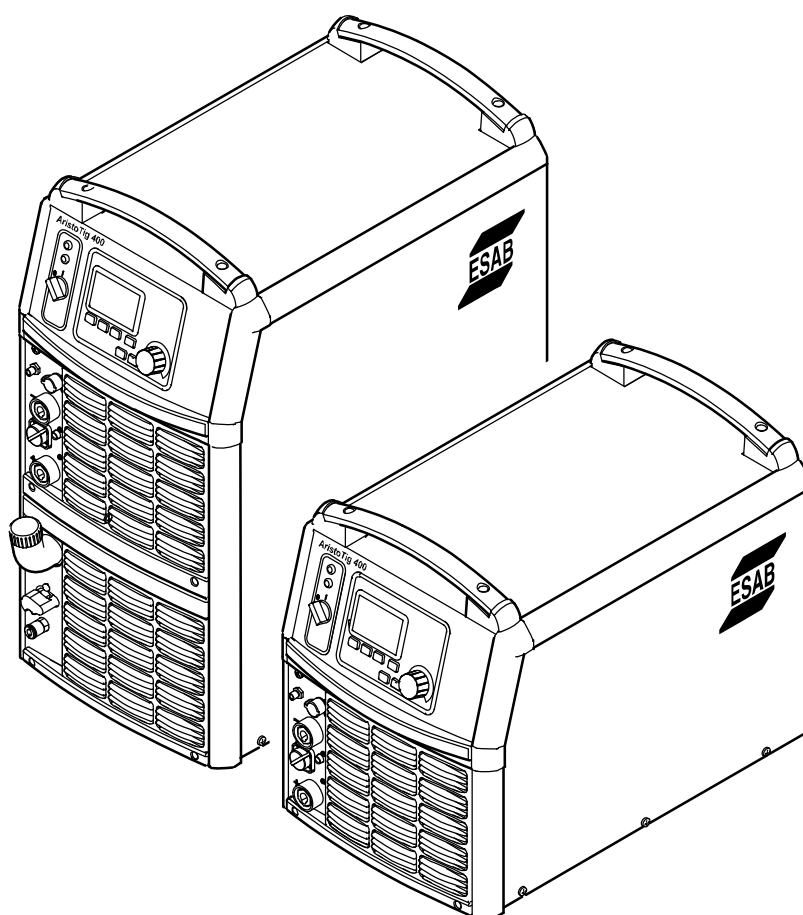

Instruction manual



DECLARATION OF CONFORMITY

According to

The Low Voltage Directive 2006/95/EC, entering into force 16 January 2007

The EMC Directive 2004/108/EC, entering into force 20 July 2007

Type of equipment

Power welding source

Type designation etc.

Tig 4000i with control panels TA4 and TA6, from serial number 802 xxx xxxx (2008 w.2)

Tig 4000i is a member of the ESAB product family Aristo®

Brand name or trade mark

ESAB

Manufacturer or his authorised representative established within the EEA

Name, address, telephone No, telefax No:

ESAB AB

Esabvägen, SE-695 81 LAXÅ, Sweden

Phone: +46 584 81 000, Fax: +46 584 411 924

The following harmonised standard in force within the EEA has been used in the design:

EN 60974-1, Arc welding equipment – Part 1: Welding power sources

EN 60974-2, Arc welding equipment – Part 2: Liquid cooling systems

EN 60974-3, Arc welding equipment – Part 3: Arc striking and stabilizing devices

EN 60974-10, Arc welding equipment – Part 10: Electromagnetic compatibility (EMC) requirements

Additional information: Restrictive use, Class A equipment, intended for use in locations other than residential

By signing this document, the undersigned declares as manufacturer, or the manufacturer's authorised representative established within the EEA, that the equipment in question complies with the safety requirements stated above.

Date
Laxå 2008-01-04

Signature

A handwritten signature in black ink, appearing to read "Kent Eimbrodt".

Kent Eimbrodt

Clarification

Position
Global Director
Equipment and Automation

1 SAFETY	4
2 INTRODUCTION	6
2.1 Equipment	6
2.2 The control panel	6
3 TECHNICAL DATA	7
4 INSTALLATION	8
4.1 Lifting instructions	8
4.2 Placing	8
4.3 Mains power supply	9
5 OPERATION	10
5.1 Connections and control devices	10
5.2 Turning on the power source	10
5.3 Fan control	11
5.4 Overheating protection	11
5.5 Cooling unit	11
5.6 Remote control unit	11
6 MAINTENANCE	12
6.1 Daily	13
6.2 If necessary	13
6.3 Every year	14
7 FAULT TRACING	14
8 ORDERING OF SPARE PARTS	14
DIAGRAM	16
ORDERING NUMBER	19
SPARE PARTS LIST	20
ACCESSORIES	21

1 SAFETY

Users of ESAB equipment have the ultimate responsibility for ensuring that anyone who works on or near the equipment observes all the relevant safety precautions. Safety precautions must meet the requirements that apply to this type of equipment. The following recommendations should be observed in addition to the standard regulations that apply to the workplace.

All work must be carried out by trained personnel well-acquainted with the operation of the equipment. Incorrect operation of the equipment may lead to hazardous situations which can result in injury to the operator and damage to the equipment.

1. Anyone who uses the equipment must be familiar with:
 - its operation
 - location of emergency stops
 - its function
 - relevant safety precautions
 - welding and cutting
2. The operator must ensure that:
 - no unauthorized person is stationed within the working area of the equipment when it is started up.
 - no-one is unprotected when the arc is struck
3. The workplace must:
 - be suitable for the purpose
 - be free from drafts
4. Personal safety equipment
 - Always wear recommended personal safety equipment, such as safety glasses, flame-proof clothing, safety gloves.
 - Do not wear loose-fitting items, such as scarves, bracelets, rings, etc., which could become trapped or cause burns.
5. General precautions
 - Make sure the return cable is connected securely.
 - Work on high voltage equipment **may only be carried out by a qualified electrician.**
 - Appropriate fire extinguishing equipment must be clearly marked and close at hand.
 - Lubrication and maintenance must **not** be carried out on the equipment during operation.



WARNING



Arc welding and cutting can be injurious to yourself and others. Take precautions when welding and cutting. Ask for your employer's safety practices which should be based on manufacturers' hazard data.

ELECTRIC SHOCK - Can kill

- Install and earth the unit in accordance with applicable standards.
- Do not touch live electrical parts or electrodes with bare skin, wet gloves or wet clothing.
- Insulate yourself from earth and the workpiece.
- Ensure your working stance is safe.

FUMES AND GASES - Can be dangerous to health

- Keep your head out of the fumes.
- Use ventilation, extraction at the arc, or both, to take fumes and gases away from your breathing zone and the general area.

ARC RAYS - Can injure eyes and burn skin.

- Protect your eyes and body. Use the correct welding screen and filter lens and wear protective clothing.
- Protect bystanders with suitable screens or curtains.

FIRE HAZARD

- Sparks (spatter) can cause fire. Make sure therefore that there are no inflammable materials nearby.

NOISE - Excessive noise can damage hearing

- Protect your ears. Use earmuffs or other hearing protection.
- Warn bystanders of the risk.

MALFUNCTION - Call for expert assistance in the event of malfunction.

Read and understand the instruction manual before installing or operating.

PROTECT YOURSELF AND OTHERS!



CAUTION

Read and understand the instruction manual before installing or operating.

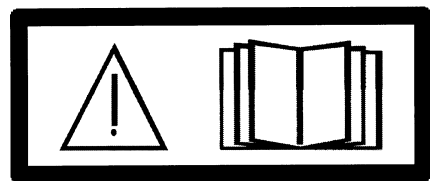

WARNING

Do not use the power source for thawing frozen pipes.



CAUTION

This product is solely intended for arc welding.



CAUTION

Class A equipment is not intended for use in residential locations where the electrical power is provided by the public low-voltage supply system. There may be potential difficulties in ensuring electromagnetic compatibility of class A equipment in those locations, due to conducted as well as radiated disturbances.

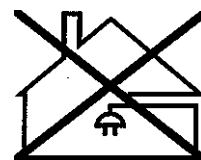

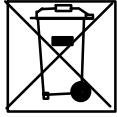

Dispose of electronic equipment at the recycling facility!

In observance of European Directive 2002/96/EC on Waste Electrical and Electronic Equipment and its implementation in accordance with national law, electrical and/or electronic equipment that has reached the end of its life must be disposed of at a recycling facility.

As the person responsible for the equipment, it is your responsibility to obtain information on approved collection stations.

For further information contact the nearest ESAB dealer.

ESAB can provide you with all necessary welding protection and accessories.

2 INTRODUCTION

The **Tig 4000i** is a TIG welding power source, which can also be used for MMA welding.

NB: These instructions describe an Tig 4000i with cooling unit.

ESAB's accessories for the product can be found on page 21.

2.1 Equipment

The Tig 4000i is delivered with 5m return cable, instructions for power source and one instruction for the control panel.

Instruction manuals in other languages can be downloaded from the website, www.esab.com.

2.2 The control panel

The power source is supplied with one of the following control panels:

- **TA4 panel**



With a knob for adjusting the current. Other parameters are controlled by pushbuttons, with symbols in the display panel.

- **TA6 panel**



With a knob for adjusting the current. Other parameters are controlled by pushbuttons, with text in the display panel.

See the separate instructions for detailed descriptions of the control panels.

3 TECHNICAL DATA

Tig 4000i	
Mains voltage	400V ± 10%, 3~ 50 Hz
Mains supply	S _{sc min} 2.0 MVA
Primary current	
I _{max} TIG	20 A
I _{max} MMA	27 A
No-load power in the energy-saving mode, 6,5 min. after welding	60 W
Voltage/current range	
TIG	8-60 V / 4-400 A
MMA	16 - 400 A
Permissible load at TIG	
35% duty cycle	400 A / 26 V
60 % duty cycle	320 A / 23 V
100% duty cycle	250 A / 20 V
Permissible load at MMA	
35% duty cycle	400 A / 36 V
60 % duty cycle	320 A / 33 V
100% duty cycle	250 A / 30 V
Power factor at maximum current	0.90
Efficiency at maximum current	86 %
Open-circuit voltage U₀ max	
without VRD function ¹⁾	78 - 90 V
U _{OL} "Live TIG", VRD function deactivated ²⁾	60 V
MMA, VRD function deactivated ²⁾	58 V
VRD function activated ²⁾	<35 V
Operating temperature range	-10 to + 40° C
Transportation temperature	-20 to +55° C
Dimensions, lxbxh	
with cooling unit	625 x 394 x 496 625 x 394 x 776
Continual sound pressure at no-load	<70 db (A)
Weight	
with cooling unit	61.5 kg 81.5 kg
Insulation class	H
Enclosure class	IP 23
Application class	S

1) Valid for power sources without VRD specification on the rating plate.

2) Valid for power sources with VRD specification on the rating plate. The VRD function is explained in the instructions for the control panel, if the panel has that function.

Duty cycle

The duty cycle refers to the time as a percentage of a ten-minute period that you can weld or cut at a certain load without overloading. The duty cycle is valid for 40° C.

Enclosure class

The IP code indicates the enclosure class, i. e. the degree of protection against penetration by solid objects or water. Equipment marked **IP23** is designed for indoor and outdoor use.

Application class

The symbol **S** indicates that the power source is designed for use in areas with increased electrical hazard.

Mains supply, S_{sc} min

Minimum short circuit power on the network in accordance with IEC 61000-3-12

Cooling unit	
Cooling power	2.0 kW at 40° C temperature difference and flow 1.0 l/min
Coolant	50 % water / 50% mono-ethylen glycol
Liquid quantity	5.5 l
Maximum water flow	2.0 l/min
Maximum number of water-cooled welding guns/torches that may be connected	two MIG welding guns or one TIG torch and one MIG welding gun

4 INSTALLATION

The installation must be carried out by a professional.

Note

Mains supply requirements

High power equipment may, due to the primary current drawn from the mains supply, influence the power quality of the grid. Therefore connection restrictions or requirements regarding the maximum permissible mains impedance or the required minimum supply capacity at the interface point to the public grid may apply for some types of equipment (see technical data). In this case it is the responsibility of the installer or user of the equipment to ensure, by consultation with the distribution network operator if necessary, that the equipment may be connected.

4.1 Lifting instructions

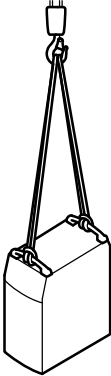
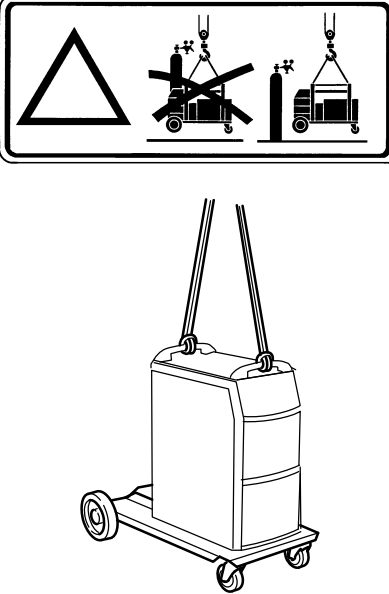
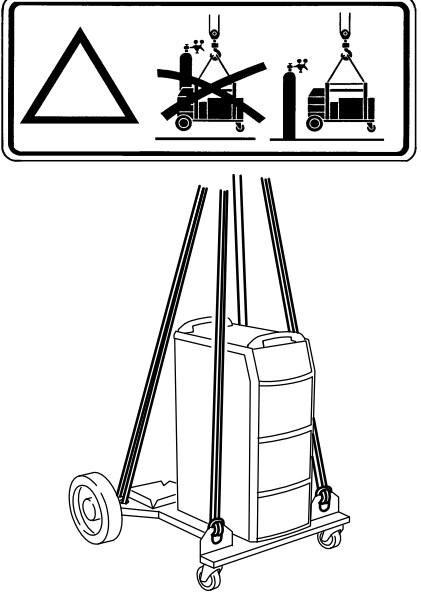
With power source	With trolley and power source	With trolley2 and power source
 <p style="text-align: right; font-size: small;">AH 0649</p>		

4.2 Placing

Position the welding power source such that its cooling air inlets and outlets are not obstructed.

4.3 Mains power supply

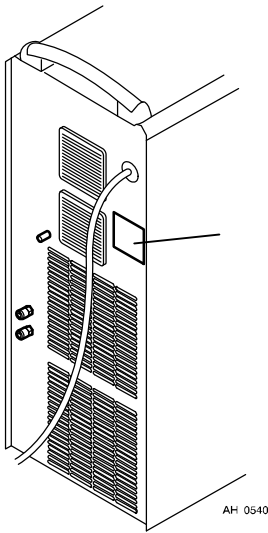

Check that the unit is connected to the correct mains power supply voltage, and that it is protected by the correct fuse sizes. A protective earth connection must be made, in accordance with regulations.

Rating plate with supply connection data.

Recommended fuse sizes and minimum cable areas

Tig 4000i	50 Hz
Mains voltage	400 V
Mains cable area, mm²	4G4
Phase current, I_{1eff}	16 A
Fuse	
Anti-surge	20 A
Type C MCB	20 A

NB:

The mains cable areas and fuse sizes as shown above are in accordance with Swedish regulations. They may not be applicable in other countries: make sure that the cable area and fuse sizes comply with the relevant national regulations.

5 OPERATION

General safety regulations for handling of the equipment can be found on page 4. Read through before you start using the equipment!

5.1 Connections and control devices

- | | | | |
|---|--|----|--|
| 1 | Connection for cooling water from the TIG torch - RED | 9 | Main power supply switch, 0 / 1 / START |
| 2 | Connection with water lock for cooling water to the TIG torch - BLUE | 10 | White indicating lamp - Power supply ON |
| 3 | Cooling water filler | 11 | Orange indicating lamp - Overheating |
| 4 | Connection for return cable (+) | 12 | Control panel (see the respective instructions) |
| 5 | Connection for remote control | 13 | Connection for gas hose |
| 6 | Connection for welding cable (-) | 14 | Connection for cooling water. <i>Not used on this model.</i> |
| 7 | Connection for start signal from the welding torch | 15 | Connection for cooling water. <i>Not used on this model.</i> |
| 8 | Connection for gas to the TIG torch | | |

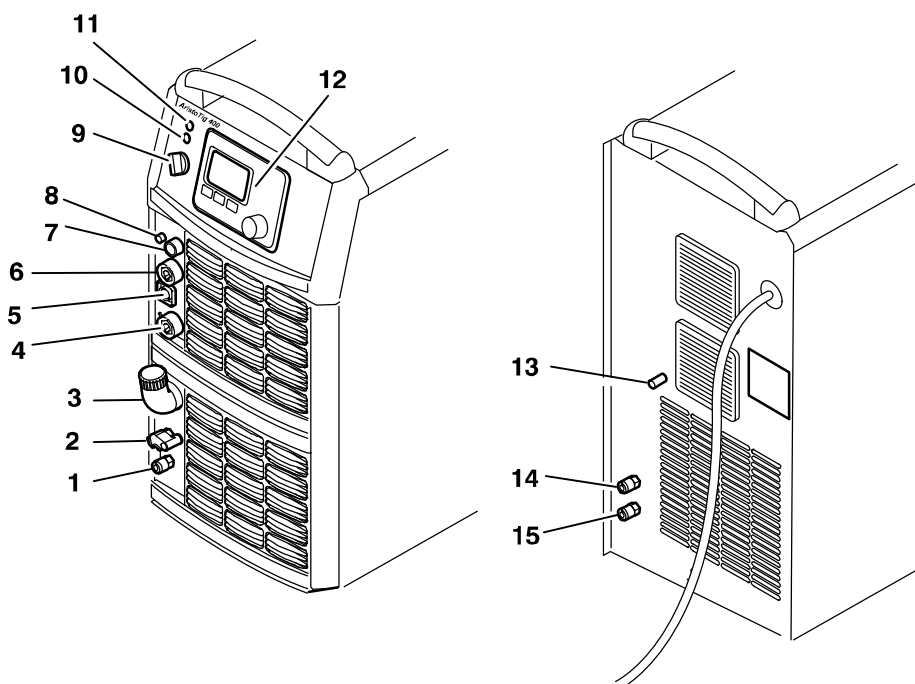

5.2 Turning on the power source

Turn on the mains power by turning switch (9) to the "START" position. Release the switch, and it will return to the "1" position.

If the mains power supply should be interrupted while welding is in progress, and then be restored, the power source will remain de-energised until the switch is again turned manually to the "START" position.

Turn the unit off by turning the switch to the "0" position

Whether in the event of a loss of power supply or of turning the power source off in the normal manner, welding data will be stored so that it is available next time the unit is started.

5.3 Fan control

The power source fans continue to run for 6,5 minutes after welding has stopped, and the unit switches to energy-saving mode. They start again when welding restarts.

The fans run at reduced speed for welding currents up to 144 A, and at full speed for higher currents.

5.4 Overheating protection

The power source has two thermal overload trips which operate if the internal temperature becomes too high, interrupting the welding current and lighting the orange indicating lamp on the front of the unit. They reset automatically when the temperature has fallen.

5.5 Cooling unit

Water lock

The cooling unit has a water lock that senses whether the cooling water hoses are connected.

The power source On/Off switch must be in the "0" position (Off) when connecting a water-cooled TIG torch.

If a water-cooled TIG torch is connected, the water pump starts automatically when the main On/Off switch is turned to "START" and/or when welding starts. After welding, the pump continues to run for 6,5 minutes, and then switches to the energy-saving mode.

Function when welding

To start welding, the welder presses the torch trigger switch. The power source energises the torch and starts wire feed and the cooling water pump.

To stop welding, the welder releases the torch trigger switch. The welding current is interrupted, but the cooling water pump continues to run for 6,5 minutes, after which the unit switches to energy-saving mode.

Water flow guard

The water flow guard interrupts the welding current in the event of loss of coolant, and displays an error message on the control panel. The water flow guard is an accessory.

5.6 Remote control unit

Aristo machines with integral control panels should have program version 1.21 or higher, in order for the remote control to function correctly.

When the remote control unit is connected, the power source and wire feed unit are in remote control mode; the buttons and knobs are blocked. The functions can only be adjusted via the remote unit.

If the remote control unit is not to be used, the remote control unit must be disconnected from the power source / wire feed unit, as otherwise it will remain in remote control mode.

When carrying out TIG welding, the value for the pulse current can be changed with the remote control.

For more information about the operation of the remote control unit, see the relevant operating instructions for the control panel.

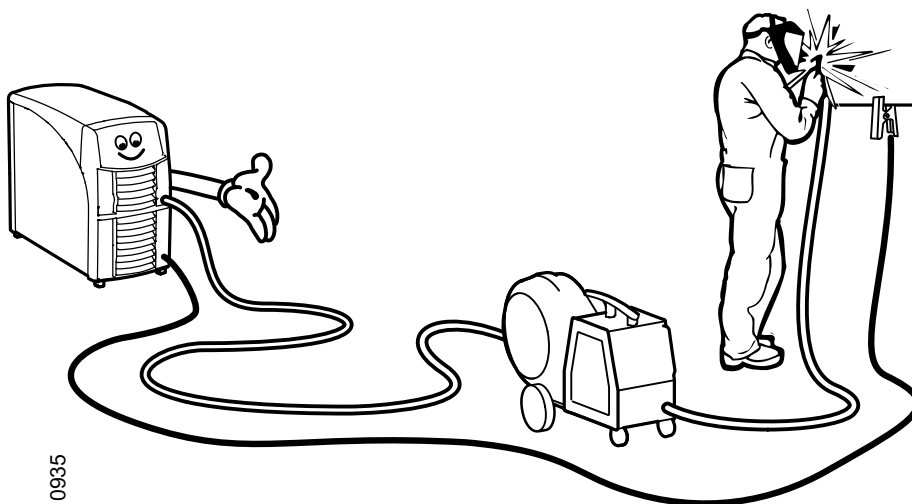
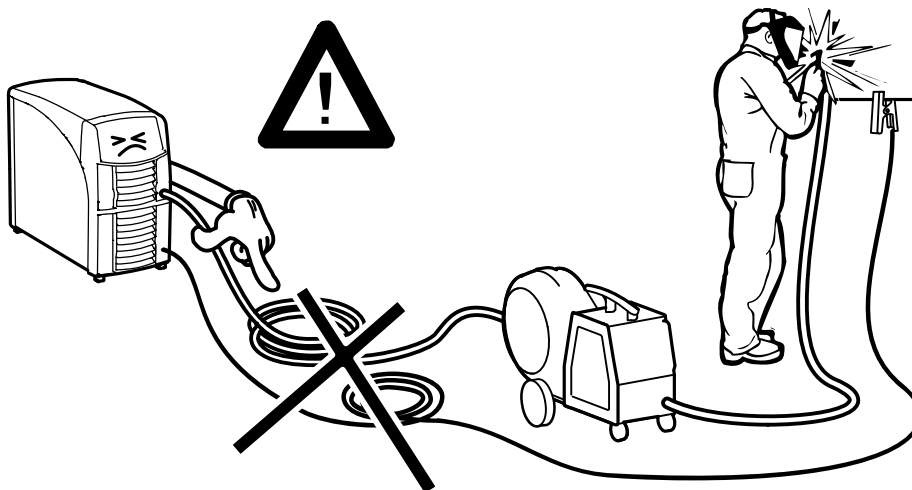

AH 0935

6 MAINTENANCE

Regular maintenance is important for safe, reliable operation.

Only personnel with the appropriate electrical skills (authorised electricians) may remove safety plates.



CAUTION

All guarantee undertakings from the supplier cease to apply if the customer attempts any work in the product during the guarantee period in order to rectify any faults.

6.1 Daily

Carry out the following maintenance every day.

- Check that all cables and connections are fault free. Tighten if necessary and replace any defective parts.
- Check the water level and water flow, top up with coolant if necessary.

6.2 If necessary

- Regularly check that the power source is not clogged with dirt. Clogged or blocked air inlets and outlets result in overheating

- Clean the dust filter

- Remove the fan grille with the dust filter (1).
- Swing out the grille (2).
- Release the dust filter (3).
- Blow the filter clean with compressed air (reduced pressure).
- Replace the filter with the finer mesh on the side against the grille (2) (out from the power source).
- Replace the fan grille with the dust filter.

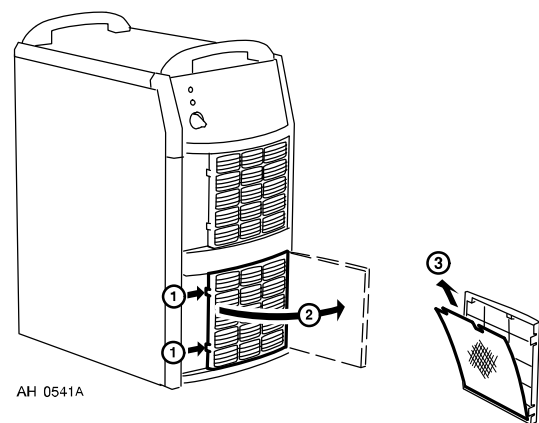

- Top up with coolant

ESAB's ready mixed coolant is recommended for use. See accessories on page 21.

- Top up with coolant until it covers half the inlet pipe.

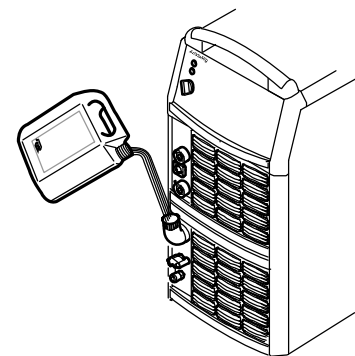

CAUTION

The coolant must be handled as chemical waste.

6.3 Every year

Carry out the following maintenance at least once a year.

- Clean off any dirt and dust. Blow the power source clean with dry compressed air (reduced pressure).
- Change the coolant and clean the hoses and water reservoir with clean water.
- Check seals, cables and connections. Tighten if necessary and replace any defective parts.

7 FAULT TRACING

Try these recommended checks and inspections before sending for an authorised service technician.

Type of fault	Action
No arc	<ul style="list-style-type: none"> • Check that the mains power supply switch is turned on. • Check that the welding current supply and return cables are correctly connected. • Check that the correct current value is set.
Welding current is interrupted during welding	<ul style="list-style-type: none"> • Check whether the thermal overload trips have operated (indicated by the orange lamp on the front panel). • Check the main power supply fuses.
The thermal overload trips operate frequently.	<ul style="list-style-type: none"> • Check to see whether the air filters are clogged. • Make sure that you are not exceeding the rated data for the power source (i.e. that the unit is not being overloaded).
Poor welding performance.	<ul style="list-style-type: none"> • Check that the welding current supply and return cables are correctly connected. • Check that the correct current value is set. • Check that the correct electrodes are being used. • Check the main power supply fuses.

8 ORDERING OF SPARE PARTS

Repair and electrical work should be performed by an authorized ESAB serviceman. Use only ESAB original spare and wear parts.

Tig 4000i is designed and tested in accordance with the international and European standards 60974-1, /-2, /-3 and 60974-10. It is the obligation of the service unit which has carried out the service or repair work to make sure that the product still conforms to the said standard.

Spare parts may be ordered through your nearest ESAB dealer, see the last page of this publication.

Diagram

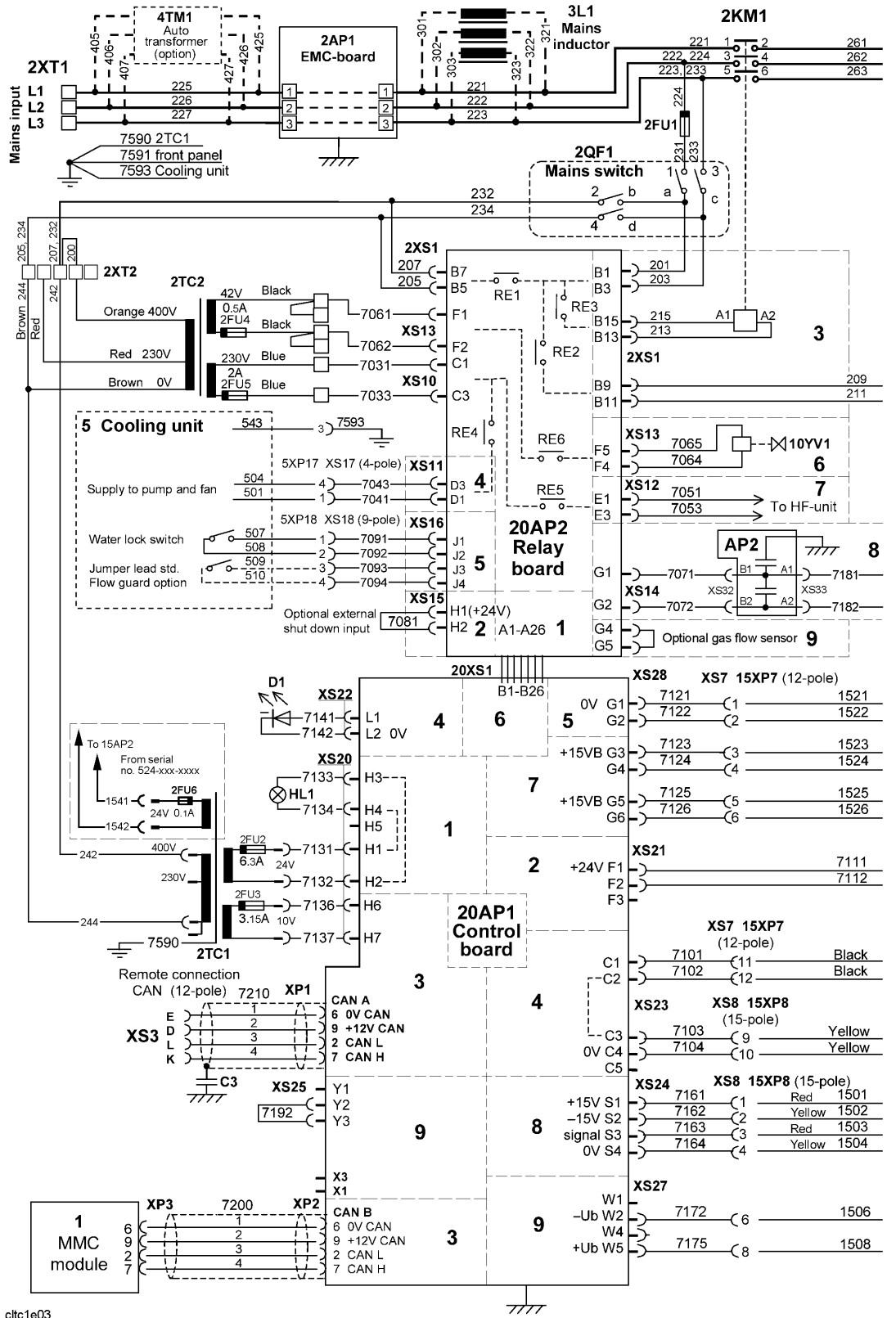

ctc1e03

Cooling unit

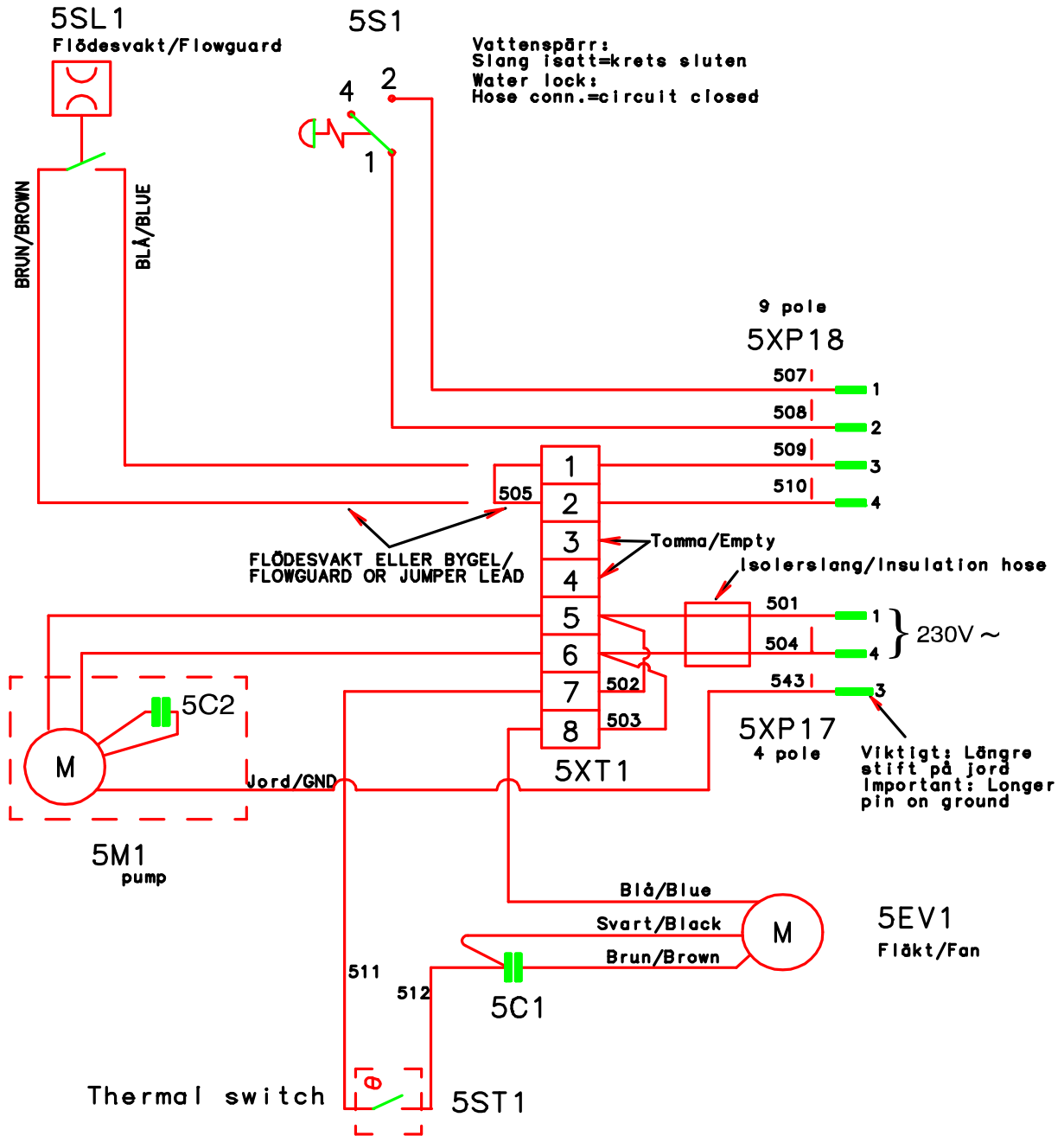

Tig 4000i

Ordering number

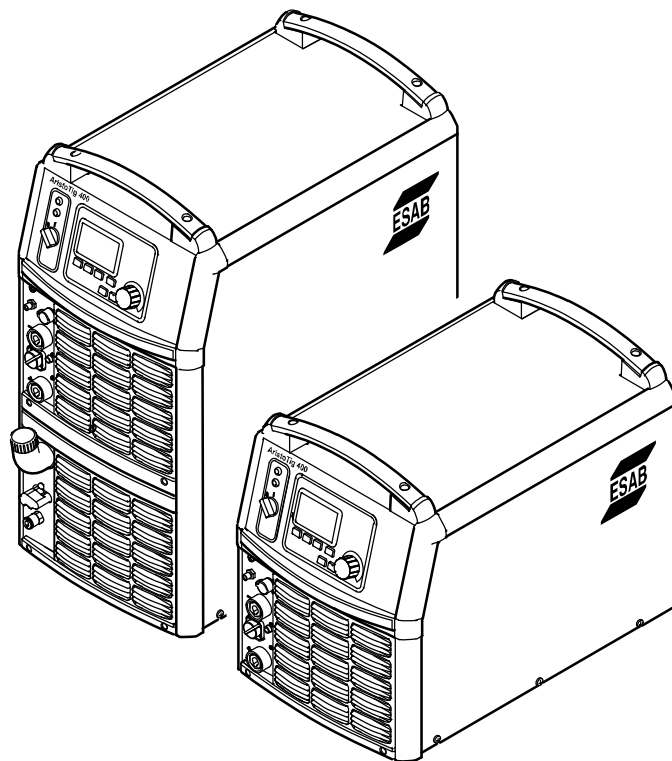

Ordering no.	Denomination	Type	Notes
0458 630 880	Welding power source	Aristo [®] Tig 4000i, TA4	with cooling unit
0458 630 881	Welding power source	Aristo [®] Tig 4000i, TA4	
0458 630 884	Welding power source	Aristo [®] Tig 4000i, TA6	
0458 630 885	Welding power source	Aristo [®] Tig 4000i, TA6	
0458 640 990	Spare part list	Aristo [®] Tig 4000i	
0458 819 xxx	Instruction manual	Aristo [®] TA4	
0458 855 xxx	Instruction manual	Aristo [®] TA6	

Instruction manuals and the spare parts list are available on the Internet at www.esab.com

Tig 4000i





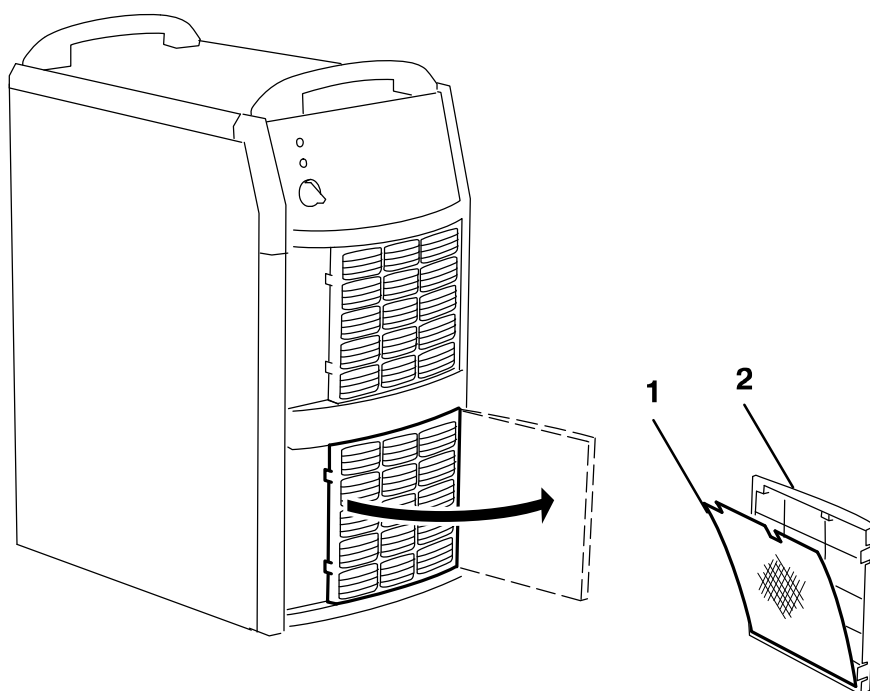

Spare parts list

Item	Ordering no.	Denomination
1	0458 398 001	Filter
2	0458 383 991	Front grill

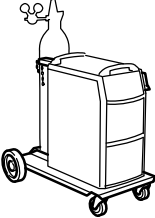
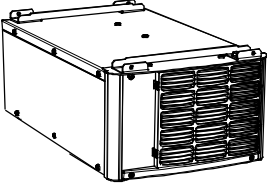

Tig 4000i

Accessories

	<p>Trolley 0458 530 881</p>
	<p>Autotransformer TUA2 0459 145 880</p>
	<p>Remote control adapter RA12 12 pole 0459 491 910 For analogue remote controls to CAN based equipment.</p>
	<p>Remote control unit MTA1 CAN 0459 491 880 MIG/MAG: wire feed speed and voltage MMA: current and arc force TIG: current, pulse and background current</p>
	<p>Remote control unit M1 10Prog CAN 0459 491 882 Choice of one of 10 programs MIG/MAG: voltage deviation TIG and MMA: current deviation</p>
	<p>Remote control unit AT1 CAN 0459 491 883 MMA and TIG: current</p>
	<p>Remote control unit AT1 CF CAN 0459 491 884 MMA and TIG: rough and fine setting of current</p>
	<p>Remote control unit T1 Foot CAN 0460 315 880 For CAN based TIG equipment</p>

Tig 4000i

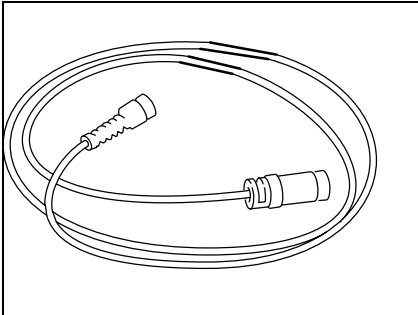
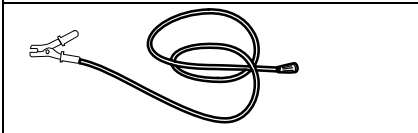
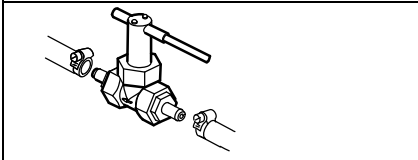
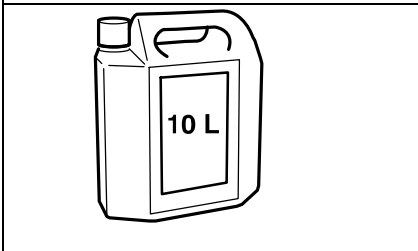
	<p>Remote cable CAN 4 pole - 12 pole</p> <p>5 m 0459 554 880</p> <p>10 m 0459 554 881</p> <p>15 m 0459 554 882</p> <p>25 m 0459 554 883</p> <p>0.25 m 0459 554 884</p>
	<p>Return cable 5 m 70 mm² 0700 006 895</p>
	<p>Water flow guard 0.7 l/min 0456 855 880</p>
	<p>Coolant (Ready mixed) 50% water and 50% mono-ethylene glycol (10 l) 0194 230 002</p>

ESAB subsidiaries and representative offices

Europe

AUSTRIA

ESAB Ges.m.b.H
Vienna-Liesing
Tel: +43 1 888 25 11
Fax: +43 1 888 25 11 85

BELGIUM

S.A. ESAB N.V.
Brussels
Tel: +32 2 745 11 00
Fax: +32 2 745 11 28

BULGARIA

ESAB Kft Representative Office
Sofia
Tel/Fax: +359 2 974 42 88

THE CZECH REPUBLIC

ESAB VAMBERK s.r.o.
Vamberk
Tel: +420 2 819 40 885
Fax: +420 2 819 40 120

DENMARK

Aktieselskabet ESAB
Herlev
Tel: +45 36 30 01 11
Fax: +45 36 30 40 03

FINLAND

ESAB Oy
Helsinki
Tel: +358 9 547 761
Fax: +358 9 547 77 71

FRANCE

ESAB France S.A.
Cergy Pontoise
Tel: +33 1 30 75 55 00
Fax: +33 1 30 75 55 24

GERMANY

ESAB GmbH
Solingen
Tel: +49 212 298 0
Fax: +49 212 298 218

GREAT BRITAIN

ESAB Group (UK) Ltd
Waltham Cross
Tel: +44 1992 76 85 15
Fax: +44 1992 71 58 03

ESAB Automation Ltd
Andover
Tel: +44 1264 33 22 33
Fax: +44 1264 33 20 74

HUNGARY

ESAB Kft
Budapest
Tel: +36 1 20 44 182
Fax: +36 1 20 44 186

ITALY

ESAB Saldatura S.p.A.
Bareggio (Mi)
Tel: +39 02 97 96 8.1
Fax: +39 02 97 96 87 01

THE NETHERLANDS

ESAB Nederland B.V.
Amersfoort
Tel: +31 33 422 35 55
Fax: +31 33 422 35 44

NORWAY

AS ESAB
Larvik
Tel: +47 33 12 10 00
Fax: +47 33 11 52 03

POLAND

ESAB Sp.zo.o.
Katowice
Tel: +48 32 351 11 00
Fax: +48 32 351 11 20

PORTUGAL

ESAB Lda
Lisbon
Tel: +351 8 310 960
Fax: +351 1 859 1277

ROMANIA

ESAB Romania Trading SRL
Bucharest
Tel: +40 316 900 600
Fax: +40 316 900 601

RUSSIA

LLC ESAB
Moscow
Tel: +7 (495) 663 20 08
Fax: +7 (495) 663 20 09

SLOVAKIA

ESAB Slovakia s.r.o.
Bratislava
Tel: +421 7 44 88 24 26
Fax: +421 7 44 88 87 41

SPAIN

ESAB Ibérica S.A.
Alcalá de Henares (MADRID)
Tel: +34 91 878 3600
Fax: +34 91 802 3461

SWEDEN

ESAB Sverige AB
Gothenburg
Tel: +46 31 50 95 00
Fax: +46 31 50 92 22

ESAB international AB
Gothenburg

Tel: +46 31 50 90 00
Fax: +46 31 50 93 60

SWITZERLAND

ESAB AG
Dietikon
Tel: +41 1 741 25 25
Fax: +41 1 740 30 55

UKRAINE

ESAB Ukraine LLC
Kiev
Tel: +38 (044) 501 23 24
Fax: +38 (044) 575 21 88

North and South America

ARGENTINA

CONARCO
Buenos Aires
Tel: +54 11 4 753 4039
Fax: +54 11 4 753 6313

BRAZIL

ESAB S.A.
Contagem-MG
Tel: +55 31 2191 4333
Fax: +55 31 2191 4440

CANADA

ESAB Group Canada Inc.
Mississauga, Ontario
Tel: +1 905 670 02 20
Fax: +1 905 670 48 79

MEXICO

ESAB Mexico S.A.
Monterrey
Tel: +52 8 350 5959
Fax: +52 8 350 7554

USA

ESAB Welding & Cutting Products
Florence, SC
Tel: +1 843 669 44 11
Fax: +1 843 664 57 48

Asia/Pacific

CHINA

Shanghai ESAB A/P
Shanghai
Tel: +86 21 2326 3000
Fax: +86 21 6566 6622

INDIA

ESAB India Ltd
Calcutta
Tel: +91 33 478 45 17
Fax: +91 33 468 18 80

INDONESIA

P.T. ESABindo Pratama
Jakarta
Tel: +62 21 460 0188
Fax: +62 21 461 2929

JAPAN

ESAB Japan
Tokyo
Tel: +81 45 670 7073
Fax: +81 45 670 7001

MALAYSIA

ESAB (Malaysia) Snd Bhd
USJ
Tel: +603 8023 7835
Fax: +603 8023 0225

SINGAPORE

ESAB Asia/Pacific Pte Ltd
Singapore
Tel: +65 6861 43 22
Fax: +65 6861 31 95

SOUTH KOREA

ESAB SeAH Corporation
Kyungnam
Tel: +82 55 269 8170
Fax: +82 55 289 8864

UNITED ARAB EMIRATES

ESAB Middle East FZE
Dubai
Tel: +971 4 887 21 11
Fax: +971 4 887 22 63

Africa

EGYPT

ESAB Egypt
Dokki-Cairo
Tel: +20 2 390 96 69
Fax: +20 2 393 32 13

SOUTH AFRICA

ESAB Africa Welding & Cutting Ltd
Durbanvill 7570 - Cape Town
Tel: +27 (0)21 975 8924

Distributors

For addresses and phone numbers to our distributors in other countries, please visit our home page

www.esab.com



www.esab.com

